

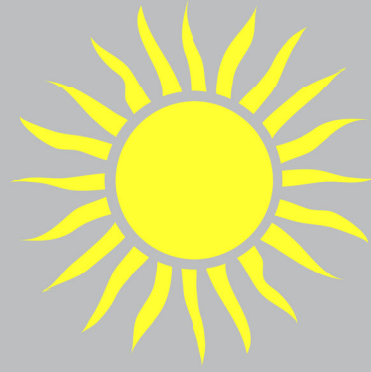

**UPPLANDS Energy Inc.**

an energy conservation company



# OFF GRID SOLAR PATHWAY LIGHTING

DECO 20 SERIES  
SOLAR PATHWAY LIGHTING  
3000L | 5000° K | SOLAR



Powered by:  
**ZeroSUN™**  
Solar Controller

ZeroSUN™ is a ground breaking solar controller technology from Upplands Energy Systems that transfers power from solar panels to the batteries and uses that power with the highest degree of efficiency. ZeroSUN™ ensures that your system operates every night, without the dependency on continuous presence of sunlight.

ZeroSUN™ smart technology has zero dependency on continuous sunlight... No more worries about cloudy, wet, rainy days affecting your solar system.

ZeroSUN™ iCloud GPRS wireless control system provides unparalleled monitoring and systems management in real time, around the clock. The iCloud GPRS control system is secure, safe, easy to use and reduces costs associated with installation and maintenance.

# OFF GRID DECO 20 SERIES - SOLAR PATHWAY LIGHTING

**MODEL:** UE-DECO-20-PB

Architectural Solar Pathway Lighting



**WARRANTY:**

3 Year Limited Warranty

**APPLICATIONS:**

The Deco 20 Decorative Solar Pathway Lighting fixture has an Architecturally pleasing design with a Hi-Performance curved monocrystalline solar panel. Coupled with our ground breaking ZeroSUN™ Smart controller technology makes Deco 20 the perfect choice for any off grid solar pathway lighting installation. Parks, gardens, walkways, anywhere critical security lighting is required. Proven solutions for worry free, all night, every night year round lighting applications.

**PRODUCT INFORMATION:**

Watts:	20W
Lumens:	3000lm max
Efficacy:	up to 180lm/watt
Battery:	Premium LiFePO4 -136.6Wh
Operating Temp:	-40°C to 60°C
Solar Panel:	Monocrystalline Solar Panel
Charge Time:	5-6hrs
Discharge Time:	7 days
CCT:	5000°K
CRI:	80
IP Rating:	IP65
Dimensions:	993.4mm X 436mm
Bat Compartment:	200mm X 249mm

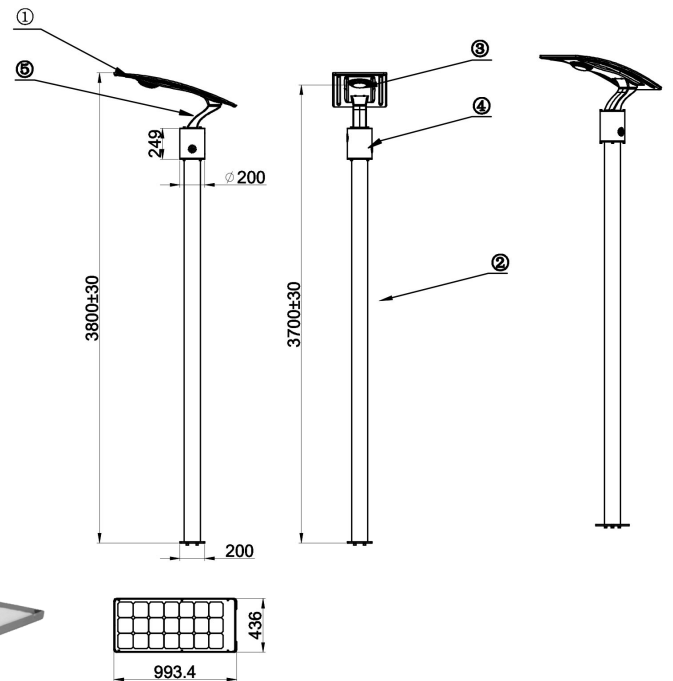

UNIT: MM

