

Date:	Project Name:
Type:	Part Number:



EMERGENCY SERIES

LED EMERGENCY LIGHT







DESCRIPTION

The Emergency Series is encased in a sturdy, all steel housing. It comes standard with a mounting canopy, three pictograms, one backplate and all mounting hardware. An external LED status indicator and test switch is standard. Powered with long life LED chips, they are the perfect choice for both new and retrofit projects.

FEATURES

- Damp location
- Steel housing & PC Material
- Thermoplastic ABS heads
- Nickel Cadmium Battery
- Easy Installation & Maintenance
- 2 hrs emergency time, Includes a 36W battery
- Operating temperature: 14°F to +104°F (-10°C to +40°C)
- For RENO-SMRC-U ***30W Battery Power, able to support 6W of remote LED heads for more than 120 min
- Test switch and charge Indicator light
- Voltage 120-347V
- 5 year warranty

APPLICATIONS

-  Commercial building
-  Hospitals
-  Retail
-  Schools

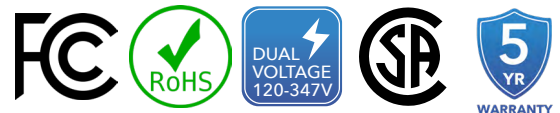

Date:	Project Name:
Type:	Part Number:

SPECIFICATION

ORDER#	MODEL#	WATTS	VOLTAGE (V)	CHARGE TIME	DISCHARGE TIME	MATERIAL	BATTERY TYPE
R61004	RENO-SRMS-U	2W	120-347V	8 Hours	>2 hours	Powder Coated Steel	Sealed Nickel-Cadmium
R61005	RENO-SRMC-U	2x5W (940lm)	120-347V	24 Hours	>2 hours	Powder Coated Steel	Sealed Nickel-Cadmium

REMOTE HEAD OPTIONS

ORDER#	MODEL#	DESCRIPTION
R61101	RENO-ERH2W-1	2W LED Head
R61103	RENO-ERH2W-2	2x2W LED Heads

PICTOGRAMS INCLUDED

No Indicator



Left Indicator



Right Indicator



Date:	Project Name:
Type:	Part Number:

DIMENSIONS

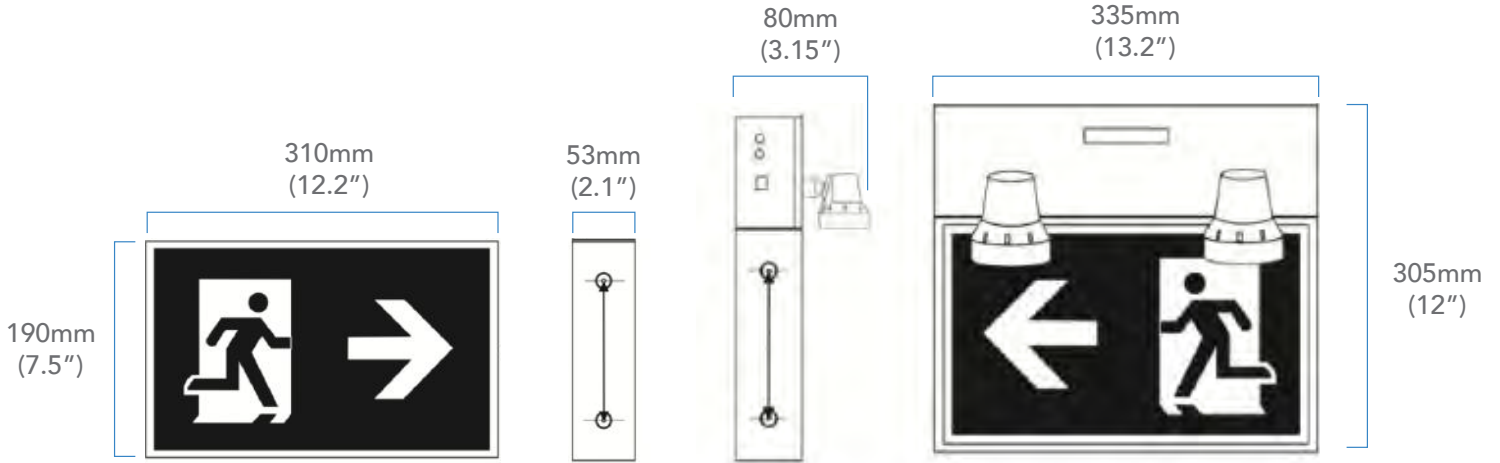

MOUNTING OPTIONS

Flag Mount

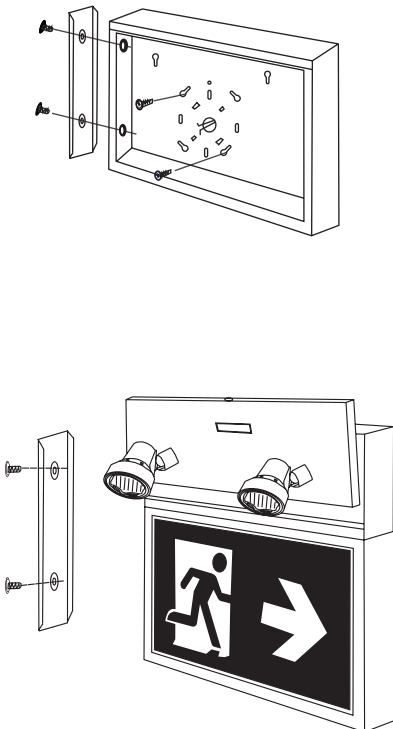

Wall Mount

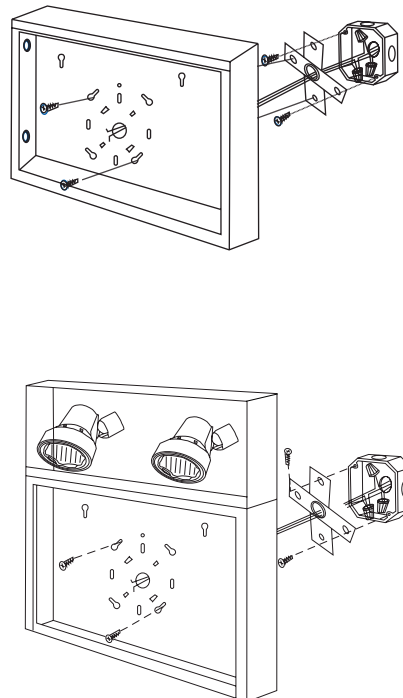

Ceiling Mount

