

Date:	Project Name:
Type:	Part Number:



HELIOS SERIES

LED WRAP AROUND

DESCRIPTION

The Helios series embraces a minimalist design while providing a wide array of features making this fixture adaptable to any indoor application. Utilize the colour and wattage selections built into the fixture to create the perfect look. Easy to install and built to last, this series is sure to impress.

FEATURES

- DLC Standard
- Optional integrated sensor available
- Dual Voltage 120-347V
- 0-10V Continuous Dimming
- Surface or Suspension Mounting options
- Easy and Safe Installation
- Frosted Polycarbonate Lens
- Rated Lifetime L70(hrs): >70,000
- Operation temperature: -22°F to 122°F (-30°C to 50°C)
- Suitable for Damp Locations
- Includes Coverplate and V-Hangers
- Sensor Available
- CRI > 80
- 7 year warranty

APPLICATIONS

-  Corridors
-  Education Facilities
-  Low Bay Application
-  Multi-res/Retirement



Date:	Project Name:
Type:	Part Number:

SPECIFICATION

ORDER#	MODEL#	WATTS	VOLTAGE (V)	LUMENS	HOURS RATING	CCT (K)	DLC STANDARD
R38001	RENO-HWR2-MW-DV-MCCT	12/15/18/22W	120-347V	1560/1950/ 2340/2860 lm	70,000	35/40/50K	✓
R38002	RENO-HWR4-MW-DV-MCCT	22/28/34/44W	120-347V	2860/3640/ 4420/5720 lm	70,000	35/40/50K	✓

ACCESSORIES OPTIONS

ORDER#	MODEL#	DESCRIPTION
R39204	RENO-RP	LED suspension kit
R83004	RENO-EM-C08	Emergency LED Driver



RENO-RP



RENO-EM-C08

Date:	Project Name:
Type:	Part Number:

RENO SMART NLC SYSTEM ACCESSORIES

ORDER#	MODEL#	DESCRIPTION
R75001	RENO-RS-JK-BPDN-12V	Bluetooth 3.5mm Jack PIR Sensor for RENO Smart NLC System
R75002	RENO-RS-JK-BMWM-12V	Bluetooth 3.5mm Jack Microwave Sensor for RENO Smart NLC System
R75103*	RENO-RS-JK-AD-CORD-L	Hardwire Adjustable "L" Angle Adaptor for 3.5mm Jack Sensors
R75201	RENO-RS-GW-BCNW	Ceiling Mounted Gateway for RENO Smart NLC System
R75302	RENO-RS-RC-BNNG	7-Key Smart Wall Switch for RENO Smart NLC System
R75301	RENO-RS-RC-BNNN	5-Key Reset Remote (*Requires R75103)



RENO-RS-JK-BPDN-12V



RENO-RS-JK-BMWM-12V



RENO-RS-JK-AD-CORD-L



RENO-RS-GW-BCNW



RENO-RS-RC-BNNG



RENO-RS-RC-BNNN

STANDALONE SENSOR

ORDER#	MODEL#	DESCRIPTION
R74002	RENO-SENSOR-PIR-H-EX	For external mounting when installed above 13FT



RENO-SENSOR-PIR-H-EX

Date:	Project Name:
Type:	Part Number:

STANDALONE SENSOR REMOTE

ORDER#	MODEL#	DESCRIPTION
R73002	RENO-REMOTE-H	Remote Control



RENO-REMOTE-H

DIMENSIONS

2FT.

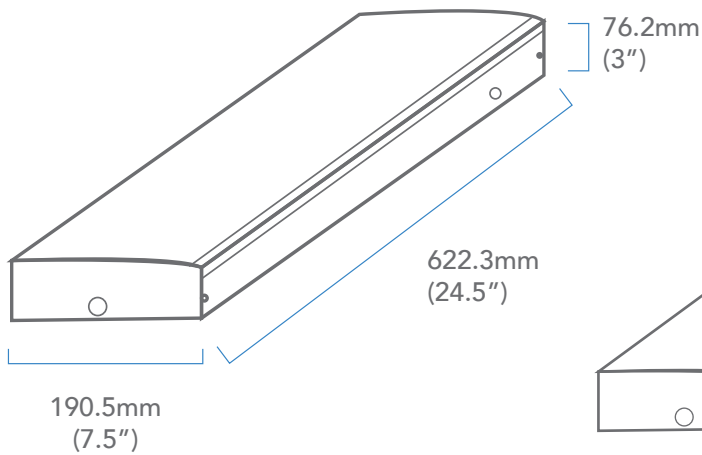

4FT.

